



Revision: 1.1 - 03/19/2010

WARNING: This installation requires lifting of the motorcycle. Serious injury can result from an improperly secured motorcycle. Ensure that the motorcycle is securely supported during this procedure.

INSTRUCTIONS:

All work must be performed by a qualified mechanic according to steps outlined in the authorized service manual.

The operator must use extreme caution when operating a modified motorcycle, particularly while familiarizing himself with its' altered handling characteristics.

Check your motorcycle for proper parking lean angle. After lowering, your sidestand may require adjustment.

INSTALLATION PROCEDURE

1. Secure motorcycle to a bike lift and raise the motorcycle. Rear wheel should remain barely resting on the ground.
2. See diagram on page 2 for references made in parentheses, for example (#1).
3. In order to gain access to the stock suspension and bolts as seen in the diagram you may need to remove/relocate several items depending on which model bike you have. The horn, exhaust, floorboard and master cylinder, may all need to be removed. Do not disconnect the brake line.
4. Once you have full access to the stock suspension, remove nut (#1) and slide out bolt (#2). This will free up the tension on the shock. Raise the back tire and remove nut (#3) and bolt (#4). Be sure to keep all bushings, spacers, o-rings, etc. in proper order to reinstall them as they were before taking them off. The stock bushings X-ed" out in the diagram on page 2 are not reused.
5. Next remove the two stock suspension arms and replace with the provided lowering kit arms. Reinstall the entire suspension assembly in the reverse order you removed it, applying Loctite to all the bolts. Make sure all bolts are tightened securely.
6. Re-install any parts removed/relocated back onto the bike. Lower bike from lift and check that all nuts and bolts are secure.

Our install guides provide a basic outline on the proper installation of our products. Further tuning and/or fitment may be required. Barons bears no responsibility on installation costs associated with this product.

© 2024 Barons Custom Accessories

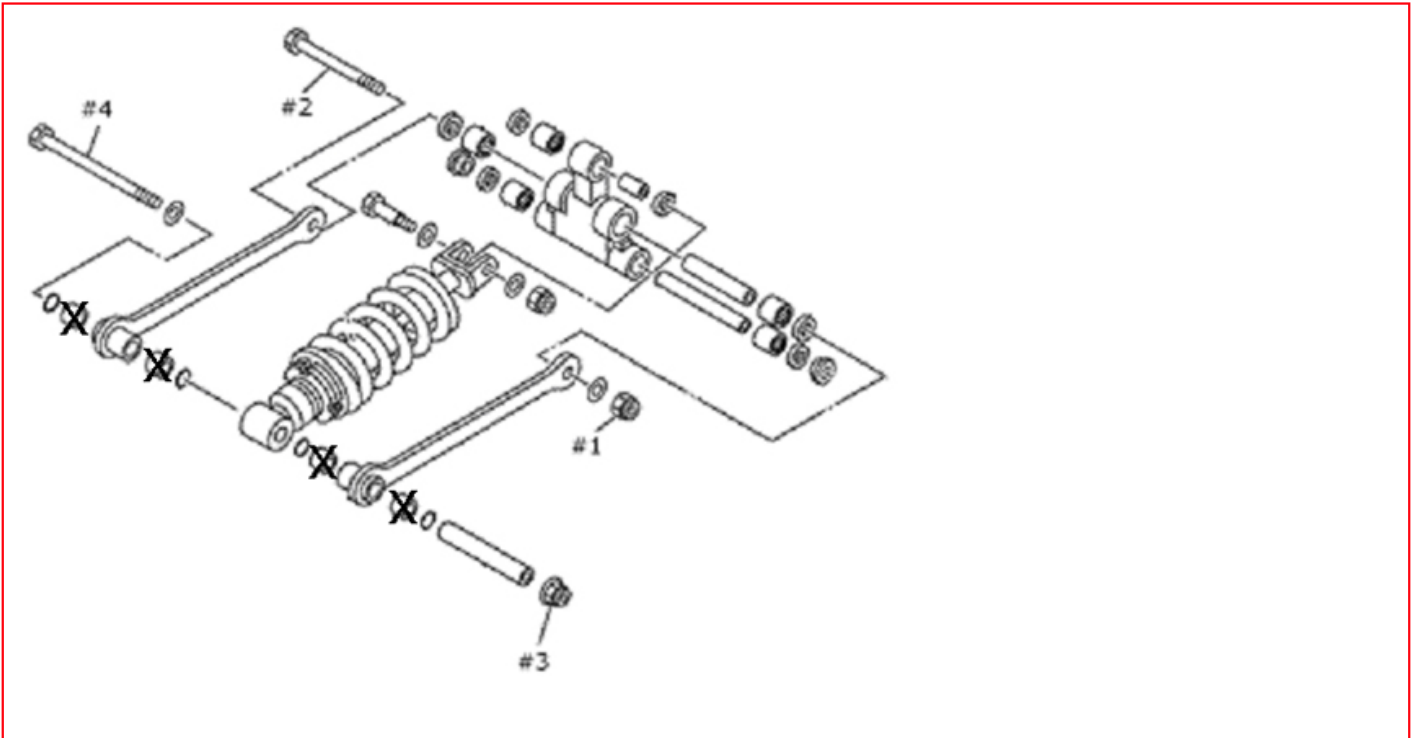

NOTE: We recommend that you set the shock spring preload to a higher setting, especially if the motorcycle will be used for carrying a passenger or heavy loads.

WARNING: Installing a lowering kit will decrease initial ground clearance. The motorcycle will be lower to the ground and care should be taken to avoid bottoming, especially over bumps or in turns. To maintain proper balanced geometry, the front and rear of the motorcycle should be lowered equally. Failure to properly install the lowering kit and operate the motorcycle after installation may result in serious injury or death to the rider.

LIMITED GUARANTY: Because we cannot control the application of our products, buyer assumes risks for any and all damage caused to him or herself or any third party by virtue of any failure of these parts. Guaranty for such parts is limited to our replacement costs thereof. This guaranty is in lieu of all other guaranties or warranties express or implied, and all other such guaranties or warranties are hereby expressly disclaimed. By installation of these parts, buyer irrevocably agrees to the foregoing.

Our install guides provide a basic outline on the proper installation of our products. Further tuning and/or fitment may be required. Barons bears no responsibility on installation costs associated with this product.
© 2024 Barons Custom Accessories