



Revision: 1.2 - 01/26/2011

LA-7502-39

39mm Front Spring Lowering Kit Harley Davidson

Page: 1

WARNING: This installation requires lifting of the motorcycle. Serious injury can result from an improperly secured motorcycle. Ensure that the motorcycle is securely supported during this procedure.

INSTRUCTIONS:

All work must be performed by a qualified mechanic according to steps outlined in the authorized service manual.

To maintain proper balanced geometry, we recommend lowering the front and rear of the motorcycle equally. LA Choppers offers rear lowering kits for your motorcycle, too.

The operator must use extreme caution when operating a modified motorcycle, particularly while familiarizing himself with its' altered handling characteristics.

Check your motorcycle for proper parking lean angle. After lowering, your sidestand may require adjustment.

Do not lower FLH models 2". *(Stock rebound spring is replaced with LA Choppers rebound spring).

INSTALLATION PROCEDURE

1. Support the motorcycle so the front wheel is off the ground. Next remove the front wheel and fender. Remove the fork cap nuts and loosen the lower triple clamp pinch bolts. Remove the front brake caliper. Some models have a tapered end to the fork tube. Extra effort will be required to remove the tube from the crown. Loosen the top fork cap 1 to 2 revolutions. Use a soft wood block or similar tool (that will not mark fork cap finish) and tap down with mallet to loosen fork tube from its tapered fit in top steering crown. Make sure fork pinch bolts are loose. To completely remove fork of this style, unscrew the fork cap entirely.

2. Slide both fork assemblies out of the triple clamps. Unscrew the top fork tube plugs. Remove the plugs and fork springs. CAUTION: Fork caps are under spring pressure and could cause serious injury. Drain the fork oil by turning the fork assemblies upside-down.

3. Next, bottom the fork tube into the fork leg. DO NOT extend the tube while you remove the allen bolt on the bottom of the fork leg. Turn the assembly upside-down and shake the damper rod and rebound spring out of the fork assembly. Again, DO NOT extend the tube during this. Extending the tube could dislodge the internal bottoming cone, which fits on the end of the damping rod, making it very difficult to reinstall the damper rod without complete fork disassembly.

4. FOR 1" REDUCTION IN FORK LENGTH: You must first measure the length of the O.E.M. rebound spring. Depending on the model of the motorcycle, the length will either be 1" or 2" long.

A. If you currently have a 1" rebound spring, you need to replace it with the 2" long LA Choppers rebound spring (included in the kit), then reinstall the damper rod in the fork tube.

B. If you currently have a 2" rebound spring, you will need to add the 1" long spacer, then reinstall the damper rod in the fork tube.

FOR 2" REDUCTION IN FORK LENGTH: Install the long rebound spring included in the kit, and the stock rebound spring on the damper rod. Next reinstall the damper rod in the fork tube.

Our install guides provide a basic outline on the proper installation of our products. Further tuning and/or fitment may be required. LA Choppers bears no responsibility on installation costs associated with this product.

© 2019 LA Choppers

NOTE: Use Loctite on the allen bolt at the bottom of fork and torque to 18 foot lbs.

5. Slide the fork tube up and down in the fork leg. Check for smooth action and full travel.
6. Replace the fork oil with Harley-Davidson type "E" fork oil or equivalent 10wt fork oil. Heavier or more aggressive riders may prefer 15wt or 20wt fork oil. Add the amount of fork oil to your forks that is specified in your factory owners manual; adjust to your riding style.
7. Install the new progressively wound main fork spring into the fork tube with the tight coils to the top. Install one washer on top of the spring. Now check the fork spring preload with a fully extended fork. With the PVC material supplied, cut the spacer to a length that will allow the fork cap to compress the fork spring 1 1/2", with the fork cap fully tightened. **NOTE:** Some models will not require a spacer, other models may. Always check preload upon installation of this kit. Heavier or more aggressive riders may prefer 1 3/4" preload (stiffer), and lighter or less aggressive riders 1 1/4" (softer). Install a washer on top of the spacer (if applicable) and fully tighten the fork cap. Models with tapered fork tube must be installed in fork crown prior to installing fork cap.
8. Re-install the forks, caliper, front wheel and fender on the motorcycle. Check for smooth fork action, brake operation, and recheck all nuts and bolts for correct tightness.

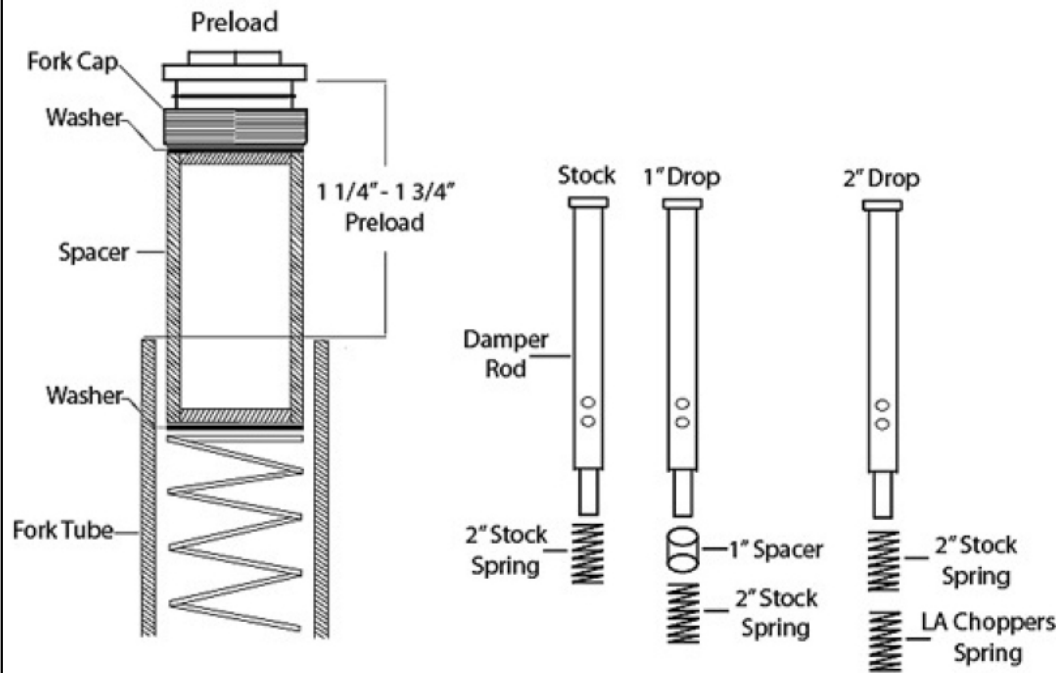

WARNING: Installing a lowering kit will decrease initial ground clearance. The motorcycle will be lower to the ground and care should be taken to avoid bottoming, especially over bumps or in turns. To maintain proper balanced geometry, the front and rear of the motorcycle should be lowered equally. Failure to properly install the lowering kit and operate the motorcycle after installation may result in serious injury or death to the rider.

LIMITED GUARANTY: Because we cannot control the application of our products, buyer assumes risks for any and all damage caused to him or herself or any third party by virtue of any failure of these parts. Guaranty for such parts is limited to our replacement costs thereof. This guaranty is in lieu of all other guaranties or

Our install guides provide a basic outline on the proper installation of our products. Further tuning and/or fitment may be required. LA Choppers bears no responsibility on installation costs associated with this product.
© 2019 LA Choppers



warranties express or implied, and all other such guaranties or warranties are hereby expressly disclaimed. By installation of these parts, buyer irrevocably agrees to the foregoing.

Our install guides provide a basic outline on the proper installation of our products. Further tuning and/or fitment may be required. LA Choppers bears no responsibility on installation costs associated with this product.
© 2019 LA Choppers